

SPECIFICATIONS

#110S Temperature Sensor

FEATURES

- Internal reference and linearization provides high accuracy.
- Universal mounting assembly mounts quickly to pipe or tower.
- Six-plate radiation shield allows accurate measurement of ambient air temperature.

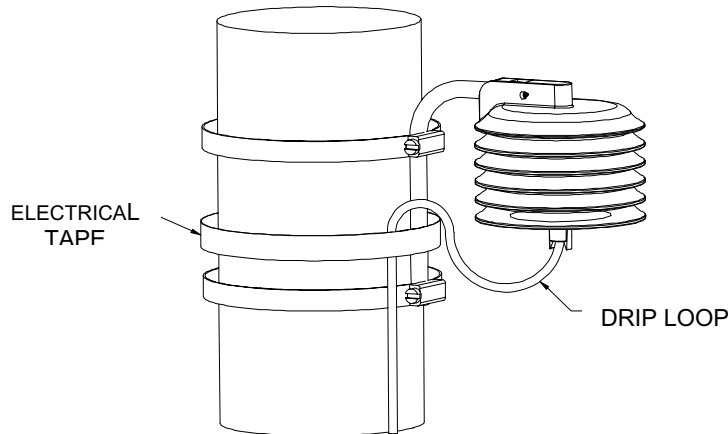

The NRG #110S temperature sensor is a low-cost, durable integrated circuit temperature sensor that provides a high level voltage output signal. The #110S includes an internal reference, amplifiers, and linearization, and a six-plate UV-stabilized radiation shield.

The sensor is ideal for collecting temperature data for energy density calculations and monitoring air temperature at remote sites.

SPECIFICATIONS

Description	Sensor type	integrated circuit temperature sensor with six plate radiation shield
	Applications	<ul style="list-style-type: none"> • wind resource assessment • meteorological studies • environmental monitoring
	Sensor range	-40 °C to 52.5 °C (-40 °F to 126.5 °F)
	Instrument compatibility	all NRG loggers
Output signal	Signal type	linear analog voltage
	Transfer function	Temp = (Voltage x 55.55) - 86.38 °C [Temp = (Voltage x 100) - 123.5 °F]
	Accuracy	<ul style="list-style-type: none"> • within +/- 1.11 °C (2 °F) • nonlinearity is +/- 0.33 °C (+/- 0.6 °F) maximum
	Electrical time constant	250 μs
	Output signal range	0 V to 2.5 V DC
Power requirements	Supply voltage	4 V to 35 V DC
	Supply current	300 μA max. (no load on output)
Response characteristics	Thermal time constant	5 minutes



Global leaders in wind assessment technology

110 Riggs Road · Hinesburg · VT 05461 USA · TEL (802) 482-2255 · FAX (802) 482-2272 · EMAIL sales@nrghsystems.com

SPECIFICATIONS

Installation	Mounting	attaches to tower with included hose clamps
	Tools required	<ul style="list-style-type: none"> • sheet metal shears or similar for trimming hose clamps • 5/16 inch hex driver or flat blade (-) screwdriver
Environmental	Operating temperature range	-40 °C to 52.5 °C (-40 °F to 126.5 °F)
	Operating humidity range	0 to 100% RH
	Lifespan	10 years +
Physical	Connections	wire leads: <ul style="list-style-type: none"> • signal (clear wire) • ground (black wire) • excitation (red wire) • shield wire for earth ground
	Cable length	5 m (16 feet)
	Weight	0.47 kg (1.04 pounds)
	Dimensions	<ul style="list-style-type: none"> • sensor only: 30.5 mm (1.2 inches) height x 12.7 mm (0.5 inch) diameter • sensor with radiation shield: 127 mm (5 inches) diameter x 127 mm (5 inches) height
Materials	Cable	3 conductor 22 AWG, with overall foil shield and drain wire, chrome PVC jacket
	Probe	aluminum, epoxy filled
	Shield	UV-stabilized thermoplastic solar radiation shield



SARTELCO SISTEMI SRL
 Via Torri Bianche,1
 20059 Vimercate (MB)
 Tel. +39-039-62905.1 Fax. +39-039-62905.99
 e-mail sistemi@sartelco.it
 www.sartelco.it

Global leaders in wind assessment technology



110 Riggs Road · Hinesburg · VT 05461 USA · TEL (802) 482-2255 · FAX (802) 482-2272 · EMAIL sales@nrgsystems.com

SPECIFICATIONS

Relative Humidity Sensor

FEATURES

- Inexpensive relative humidity measurement
- High level voltage output signal
- Long term stability



The RH-5 is a low-cost continuous measurement relative humidity sensor. It is compatible with Symphonie loggers equipped with any iPack and RH SCM, and 9300 loggers equipped with rechargeable batteries and PV panels.

The RH-5 uses a polymer resistor sensor which provides excellent linearity and sensitivity with fast response and long-term stability. Mounts to underside of shelter box. Includes 1.5 m (5 feet) cable.

SPECIFICATIONS

Description	Sensor type	polymer resistor humidity sensor
	Applications	<ul style="list-style-type: none">• wind resource assessment• meteorological studies• environmental monitoring
	Sensor range	5 to 95% relative humidity
	Instrument compatibility	Symphonie with RH5 SCM + any iPack
Output signal	Signal type	linear analog voltage
	Transfer function	% Relative Humidity = Voltage x 20
	Accuracy	+/- 5% RH from 5 to 95% RH [at 25 °C (77 °F)]
	Output signal range	0 to 5V for 0 to 100% RH, with a load resistance greater than 10 k ohms
Power requirements	Supply voltage	10 V to 36 V DC, 12 V at 1.2 mA typical
Installation	Mounting	bolts to bottom of logger shelter box with supplied hardware
	Tools required	<ul style="list-style-type: none">• #2 Phillips (+) screwdriver• 9 mm (11/32 inch) nut driver or wrench
Environmental	Operating temperature range	-40 °C to 54 °C (-40 °F to 130 °F)
	Operating humidity range	0 to 95% relative humidity



Global leaders in wind assessment technology

110 Riggs Road · Hinesburg · VT 05461 USA · TEL (802) 482-2255 · FAX (802) 482-2272 · EMAIL sales@nrghsystems.com

SPECIFICATIONS

Physical	Connections	wire leads, 3 conductor shielded cable: <ul style="list-style-type: none">• Red: Power• Black: Ground• White: Signal out
	Cable length	1.5 m (5 feet)
	Weight	0.68 kg (1.5 pounds)
	Dimensions	115 mm (4.5 inches) x 102 mm (4 inches) x 80 mm (3.1 inches)
Materials	Cable	3 conductor 22 AWG, with overall foil shield and drain wire, chrome PVC jacket
	Enclosure	Cast aluminum and stainless steel



SARTELCOTM SISTEMI SRL
Via Torri Bianche,1
20059 Vimercate (MB)
Tel. +39-039-62905.1 Fax. +39-039-62905.99
e-mail sistemi@sartelco.it
www.sartelco.it



Global leaders in wind assessment technology

110 Riggs Road · Hinesburg · VT 05461 USA · TEL (802) 482-2255 · FAX (802) 482-2272 · EMAIL sales@nrgsystems.com

SPECIFICATIONS

BP20 Barometric Pressure Sensor

FEATURES

- High level linear voltage output
- 0 to 5 V span output



The NRG #BP20 barometric pressure sensor is a micro-machined absolute pressure sensor which provides a high level voltage output signal that is proportional to absolute pressure. It includes built-in temperature compensation, linearization, and an output amplifier.

Its low cost and rugged PVC enclosure make the BP-20 ideal for collecting absolute pressure data at remote sites.

SPECIFICATIONS

Description	Sensor type	Micro-machined integrated circuit absolute pressure sensor
	Applications	<ul style="list-style-type: none"> • wind resource assessment • meteorological studies • environmental monitoring
	Sensor range	15 kPa to 115 kPa (4.43 inches to 34.0 inches Hg)
	Instrument compatibility	• NRG Symphonie equipped with a BP SCM + any iPack
Output signal	Signal type	linear analog voltage
	Transfer function	Absolute Pressure in kPa = (Voltage x 21.79) + 10.55 typical
	Accuracy	+/- 1.5 kPa max. uncorrected offset (+/- 0.443 inches Hg)
	Calibration	calibration sheet included with each sensor specifies offset correction
	Turn on time	15 ms
Power requirements	Supply voltage	7 V to 35 V DC
	Supply current	15 mA max. (8 mA typical)
Installation	Mounting	mounts directly to tower or inside steel shelter box with hose clamps (included)
	Tools required	8mm (5/16 inch) nut driver or flat blade screwdriver
Physical	Connections	wire leads, 3 conductor shielded cable: <ul style="list-style-type: none"> • Red: sensor power • White: output signal • Black: sensor ground • Shield wire: to earth ground



Global leaders in wind assessment technology

110 Riggs Road · Hinesburg · VT 05461 USA · TEL (802) 482-2255 · FAX (802) 482-2272 · EMAIL sales@nrghsystems.com

SPECIFICATIONS

	Cable length	<ul style="list-style-type: none"> • 1.5 m (5 feet) • cable diameter 4.8 mm (3/16 inches)
	Weight	0.1 kg (0.2 pounds)
	Dimensions	<ul style="list-style-type: none"> • 57 mm (2.25 inches) diameter • 112 mm (4.4 inches) length (including cable bushing)
Materials	Cable	3 conductor 22 AWG, with overall foil shield and drain wire, chrome PVC jacket
	Enclosure	weatherproof PVC

ALTITUDE CORRECTION TABLE

Use the table below to determine the additional offset to be used in barometric pressure calculations. For example, if your barometric pressure sensor is installed at a site 152 meters above sea level, you will need to add 19.2 mb to the standard offset of 650 mb, for a total offset of 669.2 mb.

ALTITUDE (FEET)	ALTITUDE (METERS)	DELTA P (mb)	DELTA P (inHg)
0	0	0.00	0.000
100	30	3.9	0.115
200	61	7.7	0.229
300	91	11.6	0.343
400	122	15.4	0.456
500	152	19.2	0.569
600	183	23	0.681
700	213	26.8	0.793
800	244	30.6	0.905
900	274	34.3	1.016
1000	305	38	1.127
1100	335	41.8	1.237
1200	366	45.5	1.347
1300	396	49.2	1.456
1400	427	52.9	1.565
1500	457	56.5	1.674
1600	488	60.2	1.782
1700	518	63.8	1.890
1800	549	67.4	1.997
1900	579	71.1	2.104
2000	610	74.7	2.211
2100	640	78.2	2.317
2200	671	81.8	2.423
2300	701	85.4	2.528
2400	732	88.9	2.633
2500	762	92.4	2.738
2600	792	96	2.842



Global leaders in wind assessment technology

110 Riggs Road · Hinesburg · VT 05461 USA · TEL (802) 482-2255 · FAX (802) 482-2272 · EMAIL sales@nrgsystems.com

SPECIFICATIONS

2700	823	99.5	2.946
2800	853	103	3.049
2900	884	106.4	3.152
3000	914	109.9	3.254
3100	945	113.3	3.357
3200	975	116.8	3.458
3300	1006	120.2	3.560
3400	1036	123.6	3.661
3500	1067	127	3.761
3600	1097	130.4	3.861
3700	1128	133.8	3.961
3800	1158	137.1	4.061
3900	1189	140.5	4.160
4000	1219	143.8	4.258
4100	1250	147.1	4.357
4200	1280	150.4	4.455
4300	1311	153.7	4.552
4400	1341	157.0	4.649
4500	1372	160.3	4.746
4600	1402	163.5	4.843
4700	1433	166.8	4.939
4800	1463	170	5.034
4900	1494	173.2	5.130
5000	1524	176.4	5.225
5100	1554	179.6	5.319
5200	1585	182.8	5.414
5300	1615	186.0	5.507
5400	1646	189.1	5.601
5500	1676	192.3	5.694
5600	1707	195.4	5.787
5700	1737	198.5	5.879
5800	1768	201.6	5.971
5900	1798	204.7	6.063
6000	1829	207.8	6.155

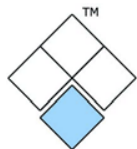

SARTELCO SISTEMI SRL

Via Torri Bianche,1
20059 Vimercate (MB)
Tel. +39-039-62905.1 Fax. +39-039-62905.99
e-mail sistemi@sartelco.it
www.sartelco.it



Global leaders in wind assessment technology

110 Riggs Road · Hinesburg · VT 05461 USA · TEL (802) 482-2255 · FAX (802) 482-2272 · EMAIL sales@nrgsystems.com

SPECIFICATIONS

Li-Cor #LI-200SA Pyranometer

FEATURES

- Measures total solar radiation
- Cosine-corrected for accurate measurement even at low sun angles

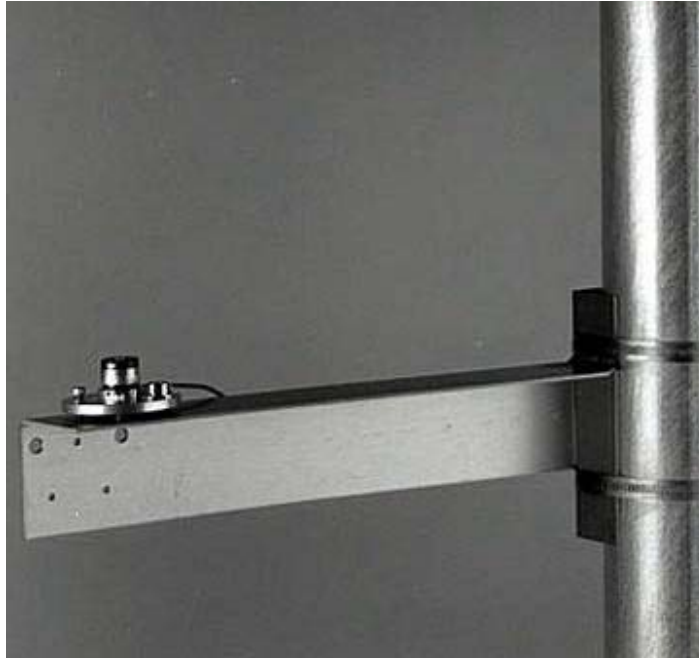

The Li-Cor Pyranometer is an excellent general purpose solar radiation sensor that is calibrated for the daylight spectrum.

The LI-200SA measures direct and reflected solar radiation and provides a small current signal compatible with all NRG 9200, 9300, and Symphonie loggers.

Includes calibration certificate, leveling base and 3 m (10 feet) of cable.

SPECIFICATIONS

Description	Sensor type	total solar radiation sensor - cosine corrected
	Applications	<ul style="list-style-type: none"> • solar resource assessment • meteorological studies • environmental monitoring
	Sensor range	0 W/m ² to 3000 W/m ²
	Instrument compatibility	<ul style="list-style-type: none"> • NRG Wind Explorer • NRG 9200-PLUS • NRG Symphonie w/ Solar SCM • any NRG 9300SA, NRG 9300CL , NRG 9300TL equipped with a VTS SIM card
Output signal	Signal type	microamp current proportional to total solar radiation
	Transfer function	<ul style="list-style-type: none"> • included on calibration certificate • typical is 90 μA per 1000 Watts/m²
	Accuracy	maximum deviation of 1% for sensor range
	Recommended load resistance	147 ohms (for voltage output), Load resistance is not required for connection to NRG Symphonie or NRG 9300SA, 9300CL, or 9300TL loggers

Global leaders in wind assessment technology



110 Riggs Road · Hinesburg · VT 05461 USA · TEL (802) 482-2255 · FAX (802) 482-2272 · EMAIL sales@nrghsystems.com

SPECIFICATIONS

	Calibration	<ul style="list-style-type: none"> • calibration sheet included with each sensor defines output in microamps per 1000 Watts/square meter • calibrated against Eppley Precision Spectral Pyranometer under natural daylight conditions.
	Output signal range	0 μ A to 270 μ A (typical)
	Drift	+/- 2% change over a 1 year period
Response characteristics	Threshold	0.1 W/m ²
Installation	Mounting	mounts to tower with custom NRG side mounting boom and hose clamps
	Tools required	<ul style="list-style-type: none"> • sheet metal shears or similar for hose clamps • 5/16 inch hex driver or flat blade screwdriver • 0.05 inch hex key (included); metric #4 allen wrench for level adjustment
Environmental	Operating temperature range	-40 °C to 65 °C (-40 °F to 149 °F)
	Operating humidity range	0 to 100%
Physical	Connections	2 bare wire leads from coaxial cable
	Cable length	3 m (10 feet)
	Weight	28 g (1.0 ounces)
	Dimensions	<ul style="list-style-type: none"> • 23.8 mm (0.94 inches) diameter • 25.4 mm (1 inch) length
Materials	Cable	shielded coaxial
	Detector	high-stability silicon photovoltaic
	Enclosure	weatherproof anodized aluminum case with acrylic diffuser and stainless steel hardware

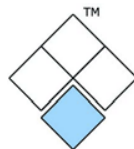

SARTELCO SISTEMI SRL

Via Torri Bianche,1
20059 Vimercate (MB)
Tel. +39-039-62905.1 Fax. +39-039-62905.99
e-mail sistemi@sartelco.it
www.sartelco.it

Global leaders in wind assessment technology



110 Riggs Road · Hinesburg · VT 05461 USA · TEL (802) 482-2255 · FAX (802) 482-2272 · EMAIL sales@nrgsystems.com